

# A Review Paper on SRF Theory Based Adaptive Hybrid Shunt Active Power Filter for Power Quality Enhancement Under Non-Linear Load

Ajit Kumar<sup>1</sup>, Vijay Anand Bharti<sup>2</sup>

<sup>1</sup>M.Tech, <sup>2</sup>Assistant Professor

<sup>1,2</sup>Department of EE, Mittal Institute of Technology, Bhopal, India

**Abstract**—The active power filter (APF) is one of power filters which give better dynamic performance. The APF requires an effective and accurate control algorithm that provides robust performance under source and load unbalances. The various used control methods are responsible for generating the reference currents which used to operate the Voltage Source Inverters (VSI). Thus, compensation of harmonics depends largely on the technique adopted, for any Shunt APF system there is various methods of implementing the control block whose output goes to gate of the voltage source Inverter. Further, the harmonic and frequency has been modelled to propose a new control strategy for the shunt Active Power Filter. The Hysteresis Control algorithm is the basic estimation algorithms which estimate the operating limit and switching sequence. The Hysteresis Control algorithm uses the hysteresis band to estimate the parameters using both low and high values. The proposed control scheme can mitigate harmonics and reactive power under nonlinear loads simultaneously. This approach is compared to the conventional shunt APF reference compensation strategy is good and effective.

## I. INTRODUCTION

In a modern electrical power system, a large quantity of power electronics equipment has been introduced. These wide range of units of power conversion, power electronic equipment and nonlinear loads such as adjustable speed drives, household appliances, saturation in transformer etc, cause increase in harmonics at the ac mains. Due to new development in technology and electronics equipment as per future requirement numbers of non-linear loads are increasing exponentially, due to this production of non-characteristic and characteristics harmonics occur in a modern power system. During last two decades the development of thyristors has brought the supple in the control but on the second side it has brought harmonics to the system also. These loads draw non sinusoidal current from ac mains and degrade the system performance [1]. By using tuned filters we can eliminate the characteristics harmonics but the non-characteristics harmonics elimination is the major problem. Non-Characteristics harmonics are different from the characterises harmonics and these are not governed by any of the order or equation.

So design of filter for these types of harmonics always not easy. The unfavourable effects of these harmonics are such as telephonic interference, more iron and cu losses and voltage resonance. Active and passive filters are mainly used out of various schemes to eliminate those harmonics. Passive filters can be designed easily for elimination of specific frequencies but for the elimination of other harmonics such as non-characteristic harmonic we must used the active power filters. For the firing of voltage source inverter (VSI) used in the Active power filter system used a various number of control algorithm. It uses APF system largely for improving reliability and performance by using control algorithm. Shunt active power filter needs an accurate control algorithm for robust performance under source and load unbalances and it is widely used in modern electric power distribution system.

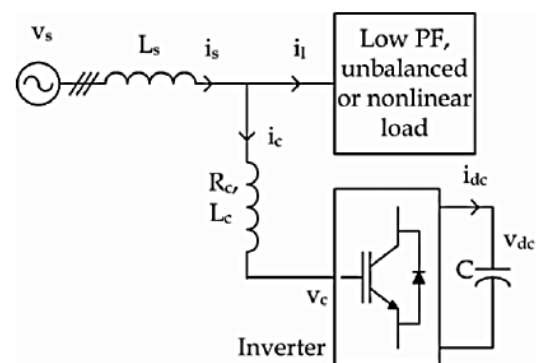

Fig.1.1 voltage source active power filter

The used of cost effective power converter circuits which raise up the performance, working efficiency, as well as the reliability of any industrial processes is common in all industry. The application areas of AC to DC and vice versa in various industries are very large and it is increasing continuously where since 1957 SCR plays very important role.

However, last two decades the wide use of single and three phase diode/thyristor rectifiers, for DC power supplies, Adjustable Speed Drives (ASD), Uninterruptible Power

Supplies (UPS), and for household and industrial appliances took place. Generally in the industrial application the energy consume by the motor utilized not more than 65% energy out of total consumption. We have to minimized the power consumption and this is the major constrain [2] to improve the profitability of any industry. Because variable speed drives reduce energy consumption (20-30% savings) and increases productivity by decreasing pollutant emission levels to environment.

## II. LITERATURE REVIEW

### 2.1 Introduction

The rapidly growing use of nonlinear loads causes considerable power quality degradation in power distribution networks, such as power harmonic distortions, and resonance problems. Active power filters (APFs) that operate as controllable power sources and offer fast response to dynamic load changes are widely used to cancel power harmonics produced by nonlinear loads]. Due to its simplicity and effectiveness, a shunt APF is the most popular tool to compensate load current harmonics. Numerous current control schemes have been proposed for shunt APFs, such as hysteresis control, proportional–integral (PI) control, proportional resonant (PR) control, and deadbeat (DB) control. However, high switching stress or inaccurate elimination of the load harmonic currents may occur due to random switching frequency for hysteresis control, sensitivity to inaccurate parameters for DB control, and failure in dealing with complex harmonic currents for both PI control and PR control. Different research papers are studied out, among all the papers are prescribed with their perspective.

[1]. **Alok K. Mishra, Prakash K. Ray.et.al (2020)** A novel switching pulse generation methodology based on adaptive fuzzy hysteresis current controlled hybrid shunt active power filter (A-F-HCC-HSAPF) is presented in this paper for compensating reactive power and harmonics in distribution network. The harmonic problems are mainly evolved because of extensive use of nonlinear loads in industry and domestic sectors. There are some adverse effects of harmonics such as: malfunctioning of sensitive equipment, resonance issues, conductors heating, power losses and reduced efficiency in distribution system. To mitigate harmonics issues passive, filters are used but when the harmonic component increases the design of passive filters is complex and becomes bulky.

[2]. **Asad Ullah, Inam Ul Hasan Sheikh, Shahzad Arshad, Faisal Saleem .et.al (2019)** Nonlinear loads are essential part of power system. With the advancement in power electronics, switching elements have major share in electrical load. These elements create nonlinearities in lines increasing the line losses, reducing power quality and

purity of sin wave. Passive filters work fine for harmonic elimination for specific frequencies which are considered in design specification. Active filters on the other hand work according to harmonics currently in line. Active filter designed in this work consists of a shunt active power filter that compensates current harmonic due to non-linear load. The active filter has a voltage source converter (VSC) which works in back to back configuration with a DC coupling capacitor.

[3]. **Shailendra Jain (2018)** These power converters utilizing switching devices are being increasingly used in industrial as well as in the domestic applications, ranging from few watts to MWs. Some applications that are increasingly being dominated by power electronics are: variable speed motor drives, switched-mode power supplies, efficient control of heating and lighting, efficient interface for photovoltaic, modern domestic appliances, fuel cell, and high-voltage DC system for efficient transmission of power, etc. These days, due to advancements in power semiconductor technology, substantial electrical power is being processed through solid state methods.

[4]. **Soumya K. Das, A.K. Ray .et.al (2017)** The harmonics are caused because of increasingly utilize of nonlinear loads connected to the power system. In this context, active power filters play a very significant role for improvement in power quality. Moreover, at transmission ground, there is a high requirement to control reactive power and voltage stability.

[5]. **Dinesh G. Nagotha and M.T. Shah .et.al (2016)** This paper present analysis of hybrid active power filter with synchronous reference frame control algorithm. The proposed topology consist of active power filter and passive power filter are connected in shunt with the mains feeding a nonlinear load. The shunt passive power filter is tuned to eliminate most dominate 5th order load current harmonic. The shunt active power filter is used compensate all other higher order load current harmonics. This approach help to reduce the overall rating of shunt active power filter, and maintain unity power factor at line side with low THD, which makes system more economical for industrial usage.

[6]. **Tzung-Lin Lee, Yen-Ching Wang, Jian-Cheng Li, and Josep M. Guerrero .et.al (2015)** Unintentional series and/or parallel resonances, due to the tuned passive filter and the line

inductance, may result in severe harmonic distortion in the industrial power system. This paper presents a hybrid active filter to suppress harmonic resonance and to reduce harmonic distortion. The proposed hybrid filter is operated as variable harmonic conductance according to the voltage

total harmonic distortion; therefore, harmonic distortion can be reduced to an

acceptable level in response to load change or parameter variation of the power system. Since the hybrid filter is composed of a seventh-tuned passive filter and an active filter in series connection, both dc voltage and kVA rating of the active filter are dramatically decreased compared with the pure shunt active filter. In real application, this feature is very attractive since the active power filter with fully power electronics is very expensive. A reasonable trade-off between filtering performances and cost is to use the hybrid active filter. Design consideration is presented, and experimental results are provided to validate effectiveness of the proposed method. Furthermore, this paper discusses filtering performances on line impedance, line resistance, voltage unbalance, and capacitive filters.

**[7]. FaizaKaddari, BenyounesMazari, Y oucefMihoub, Ahmed Safa .et.al (2014).** The purpose of this paper is to present a harmonic mitigation using a shunt active filter with

accurate harmonic current identification and compensation based on instantaneous active and reactive power theory and a self-tuning filter for the harmonic isolation and a fuzzy hysteresis band technique for the current control. In order to find the best strategy for the power quality improvement, a comparative study has been illustrated. The Analysis and simulation results using Matlab/Simulink confirm the effectiveness and limits of the proposed methods and also show the performances of fuzzy logic control which provides flexibility, high precision and fast response.

**[8]. ParagKanjiya, Bhim Singh, Ambrish Chandra, and Kamal Al-Haddad .et.al (2013).** The protection of the sensitive unbalanced nonlinear loads from sag/swell, distortion, and unbalance in supply voltage is achieved economically using the dynamic voltage restorer (DVR). A simple generalized algorithm based on basic synchronous reference- frame theory has been developed for the generation of instantaneous reference compensating voltages for controlling a DVR. This novel algorithm makes use of the fundamental positive sequence phase voltages extracted by sensing only two unbalanced and/or distorted line voltages. The algorithm is general enough to handle linear as well as nonlinear loads. The compensating voltages when injected in series with a distribution feeder by three single-phase H-bridgevoltage-source converters with a constant switching frequency hysteresis band voltage controller tightly regulate the voltage at the load terminals against any power quality problems on the source side. A capacitor-supported DVR does not need any active power during steady-state operation because the injected voltage is in quadrature with the feeder current. The

proposed control strategy is validated through extensive simulation and real-time experimental studies.

**[9]. Pablo Acuna, Luis Moran, Marco Rivera, Juan Dixon, and Jose Rodriguez .et.al (2014).** An active power filter implemented with a four-leg voltage-source inverter using a predictive control scheme is presented. The use of a four-leg voltage-source inverter allows the compensation of current harmonic components, as well as unbalanced current generated by single-phase nonlinear loads. A detailed yet simple mathematical model of the active power filter, including the effect of the equivalent power system impedance, is derived and used to design the predictive control algorithm. The compensation performance of the proposed active power filter and the associated control scheme under steady state and transient operating conditions is demonstrated through simulations and experimental results.

**[10]. Mohammed Qasim, and Vinod Khadkikar .et.al (2014)** Artificial Neural Network (ANN) is becoming an attractive estimation and regression technique in many control applications due to its parallel computing nature and high learning capability. There has been a lot of effort in employing the ANN in shunt active power filter (APF) control applications. Adaptive Linear Neuron (ADALINE) and feed-forward Multilayer Neural Network (MNN) are the most commonly used ANN techniques to extract fundamental and/or harmonic components present in the non-linear currents. This paper aims to provide an in-depth understanding on realizing ADALINE and feed-forward MNN based control algorithms for shunt APF. A step-by-step procedure to implement these ANN based techniques, in Matlab/Simulink environment, is provided. Furthermore, a detailed analysis on

the performance, limitation and advantages of both methods is presented in the paper. The study is supported by conducting both simulation and experimental validations.

**[11]. Bhim Singh, Sabha Raj Arya, Ambrish Chandra, and Kamal Al-Haddad .et.al (2014).** This paper presents an implementation of an adaptive filter in a three-phase distribution static compensator (DSTATCOM) used for compensation of linear/nonlinear loads in a three-phase distorted voltage ac mains. The proposed filter, which is based on adaptive synchronous extraction, is used for extraction of fundamental active- and reactive-power components of load currents in estimating the reference supply currents. This control algorithm is implemented on a developed DSTATCOM for reactive-power compensation, harmonics elimination, load balancing, and voltage regulation under linear and nonlinear loads. The performance of DSTATCOM is observed satisfactory under unbalanced time-varying loads.

[12]. PradeepAnjana, Vikas Gupta, HarpalTiwari .et.al (2014). In distribution systems, the load has been a sudden increase or decreases and it is like as nonlinear loads so the load draw non-sinusoidal currents from the AC mains and causes the load harmonics and reactive power, and excessive neutral currents that give pollution in power systems. Most pollution problems created in power systems are due to the nonlinear

characteristics and fast switching of power electronic devices. Shunt active filter based on current controlled PWM converters are seen as a most viable solution. This paper presents the harmonics and reactive power compensation from 3P4W micro-grid distribution system by IP controlled shunt active. The technique which is used for generate desired compensation current extraction based on offset command instantaneous currents distorted or voltage signals in the time domain because compensation time domain response is quick, easy implementation and lower computational load compared to the frequency domain.

[13]. S.K. Jain, P. Agrawal and H.O. Gupta .et.al (2002).

The simulation and experimental study of a fuzzy logic controlled, three-phase shunt active power filter to improve power quality by compensating harmonics and reactive power

required by a nonlinear load is presented. The advantage of fuzzy control is that it is based on a linguistic description and does not require a mathematical model of the system. The fuzzy control scheme is realised on an inexpensive dedicated micro-controller (INTEL 803 1) based system. The compensation process is based on sensing line currents only, an approach different from conventional methods, which require harmonics or reactive volt-ampere requirement of the load. The performance of the fuzzy logic controller is compared with a conventional PI controller. The dynamic behaviour of the fuzzy controller is found to be better than the conventional PI controller. PWM pattern generation is based on carrier less hysteresis based current control to obtain the switching signals. Various simulation and experimental results are presented under steady state and transient conditions.

[14]. Pratap Sekhar Puhan, Pravat Kumar Ray and Gayadhar Panda .et.al (2015). This work presents a comparative analysis between a single phase shunt active power filter (SPSAPF) and a single phase shunt hybrid filter (SPSHPF) to improve the power quality using different control techniques such as hysteresis current control and hysteresis fuzzy combined current control technique along with a different fuzzy rule (7/7 and 5/5) to a distribution system. An indirect current control technique

along with hysteresis current control strategy is implemented on both the filters to generate the switching signal used for turning on and off of the insulated gate bipolar transistor. The indirect current control technique that is implemented for both filters is based on extracting the source current reference from the distorted waveform of the load current. The Simulink models are prepared. Simulation results are obtained and compared for both the filters with the same

control technique, and it is observed that in every case SPSHPF shows excellent results in comparison to SPSAPF.

[15]. J. Desmet, C. Debruyne, J. Vanalme, L. Vandevelde .et.al (2010). By using the number of photovoltaic (PV) cells installed distributed generation (DG) in residential areas rapidly increases, causing some undesired side effects such as voltage rise. Overvoltage can damage critical loads, but is also disadvantageous for the owner because inverters switch off in case of overvoltage, resulting in output loss. Since grid connected inverters essentially occur nonlinear behaviour, harmonic interactions between large numbers of DG systems and the distribution network may occur. Also nonlinear loads produced harmonic currents and induce increased voltage drops in both phase and neutral conductors. This extra supply voltage drop can lead to an even more pronounced production loss of grid coupled inverters. This contribution gives some guidelines for the maximum power acceptance in a residential grid and the estimation of PV production losses due to overvoltage and discusses the influence of harmonic voltage drops.

### III. PROBLEM FORMULATION

THD or The Total Harmonic Distortion is generally used indices to measure the harmonic content of the waveform and can be applied to either current or voltage. The THD current is given by following formula.

$$THD = \frac{\sqrt{\sum_{n=2}^N I_n^2}}{I_1} \quad \text{-----} \quad (1.1)$$

Where the  $I_n$  represent the rms value of the current harmonics &  $I_1$  represent the rms value of the current component which is fundamental. However, that may be often misleading. For

that instance many adjustable speed drives will going to exhibits very high input current THD value when they are connected to very light load. When the magnitude of harmonic current is very low and relative distortion is high then these will not create a critical. Therefore characterizing the harmonic current will be main constrain to reducing the loading effect.

To account for the loading effect for characterizing the harmonic currents in a consistent fashion, the Total Demand Distortion (TDD) is nearly similar to THD except that the distortion is expressed as a percent of rated fundamental load current rather than of the fundamental current magnitude at the instant of measurement these terms are represented by IEEE Standard 519-1992. TDD is therefore given by:

$$TDD = \frac{\sqrt{\sum_{n=2}^N I_n}}{I_L}$$

Where the  $I_n$  represent the rms value of the current harmonics and  $I_L$  represent the rated demand of the fundamental current component. Hence, IEEE Standard 519-1992 recommended harmonic current limits, shown in Table 1.1, is expressed in terms of current TDD, rather than current THD. The  $I_{sc}/I_L$  ratio is the short circuit ratio at point of common coupling. As  $I_L$  seen previously,  $I_{sc}$  is the current which will be available for nonlinear load at the input side. Load is connected to it for utility purpose because a TDD limit which has been applied to the output of distribution transformer has been defined by the ratio of the short circuit. For raising the harmonic distorted voltage, distorted load current and the impedance of utility system are responsible. To limit the voltage utility is the main factor.[4] which will also produced the distortion at point of common coupling. The harmonic voltage limits are recommended by IEEE standard 519-1992 which is given in the following table 1.2, which are given for the harmonic components at maximum and THD voltage these values are given in terms of percentage of its fundamental voltage for the system which is below 69kV.

$I_{sc}/I_L$	<11	11<h<17	17<h<23	23<h<35	35<h	TDD
<20	4.0	2.0	1.5	0.6	0.3	5.0
20-50	7.0	3.5	2.5	1.0	0.5	8.0
50-100	10.0	4.5	4.0	1.5	0.7	12.0
100-1000	12.0	5.5	5.0	2.0	1.0	15.0
>1000	15.0	7.0	6.0	2.5	1.4	20.0

Note: High-voltage systems can have up to 2.0% THD where the cause is an HVDC terminal that will attenuate by the time it is tapped for a user. In this thesis, the THD indices will be used for both current and voltage. They will be distinguished by using THDI and THDV for current and voltage harmonics measurement, respectively.

#### IV. METHODOLOGY

Due to the wide spread of power electronics equipment in modern electrical power systems, the increase of the harmonics disturbance in the ac mains currents has become a more important due to the adverse effects on all equipment. Modern electrical systems, due to wide spread of power conversion units and power electronics equipment, causes an increasing harmonics disturbance in the ac mains currents.

Major Sources of harmonics:

- Non-Linear Power electronic Devices
- Saturated Core Transformer
- Uninterrupted Power Supply(UPS)
- Adjustable Speed Drives etc.

Adverse Effects of harmonics:

- Overheating of transformer
- Excessive neutral Current
- Low power factor and excessive copper and core losses
- Damage to Power drives
- Malfunction of sensitive Equipment
- Capacitor Blowing

#### 4.1 Harmonic Compensation Schemes:

Power quality has come down in the source because using a wide range of semiconductor and other non-linear devices. The causes and adverse effects of harmonics were discussed earlier; this phenomenon is also termed as harmonic pollution. There are two types of harmonic:

**4.1.1 Characteristic Harmonic-** These are always available in the system even the system is purely balanced and ideal; these harmonics are governed by certain mathematical equations. When the order of harmonics increases then its magnitude decreases. Usually even harmonics are ignored because of their dying nature due to symmetry. The order of odd harmonics is given by, where  $n$  is any natural number  $p$  is number of pulse.

**4.1.2 Non-Characteristic Harmonic-** Harmonic of the nature other than characteristic harmonics are termed as non-characteristic harmonic. It happened due to unbalance and distortion in AC voltages and unequal transformer leakage impedances. These are also called residual harmonics. By using the passive tuned filter the order of characteristic harmonics can be eliminated, whereas for elimination of latter type we need different filtering scheme. In this system for eliminating all types of harmonics use active power filter scheme. So let discuss two types of filters:

#### 3.2 Passive Filters

Passive filter is a device used as harmonic improvement in the power distribution system. These are power filters which consist of combination of passive elements like resistances (R), Inductances (L) and Capacitances (C). We can tune the circuit to bypass a harmonic frequency by proper selection of values of R, L, and C. The passive filters which are usually used in the power system are single tuned filter, double tuned filters and high pass



filters. These types of filters offer zero impedance to specific frequency and thus those are passed to ground.

### 3.3 Active Power Filter

Active Power filters have wide range application in modern electrical distribution system for

eliminating the harmonics associated with it. The Shunt active power filter (SAPF) is one of power filters which have needs an accurate control algorithm that provides robust performance and it better dynamic performance. The control methods are responsible for generating the reference currents which used to trigger the Voltage Source Inverters (VSI). Harmonic injection in power system due to various nonlinear loads such as uninterrupted power suppliers (UPS), adjustable speed drives (ASD), furnaces and single phase computer power supply etc. has resulted serious power quality problems and hence we need of Active Power filter. Most of these of non-linear loads cause harmonic injection into the power system and degrade the system performances and lower the system efficiency.

## V. MODELING & SIMULATION

The SAPF is switched to the system at 0.1 sec. The responses before and after switching can be easily distinguished from the waveform and THD values given in the table II. This section presents the MATLAB-SIMULINK based simulation results of above discussed control scheme for SAPF system. In figure 5.1 the source voltage or grid voltage is shown in figure 5.1, firstly the source voltage is measured in prescribed figure and all the entities like current, voltage and THD are measured with Shunt Active Power Filter (SAPF) and Hybrid Shunt Active Power Filter (HSAPF).

### 5.1 Response of the Shunt Active Power Filter (SAPF) and Hybrid Shunt Active Power Filter (HSAPF):

In figure 5.1 the source side voltage is shown, which is three phase voltage and balanced, provided to the nonlinear three phase load. That means harmonics will be arises with it. The quality is measured by FFT analysis.

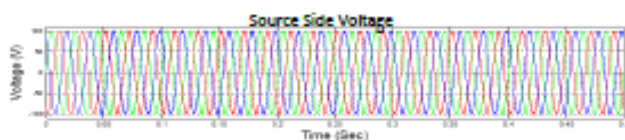

Fig.5.1. Source side voltage (SAPF)

In figure 5.2 the grid or source current is shown, here we can see that for initially certain time of interval (from 0 to .65 sec.) it is not proper due to nonlinear load with HSAPF arrangement.

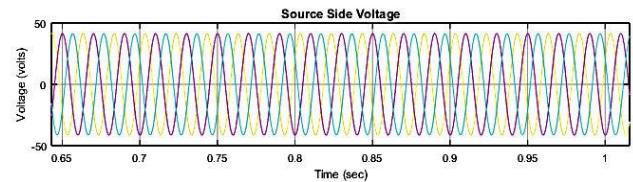

Fig.5.2. Source side voltage (HSAPF)

The figure 5.3 showing the load side voltage for the SAPF, while the load is nonlinear, the quality of signal can also be seen in the waveform. The quality of the signal is to be measured by the FFT analysis.

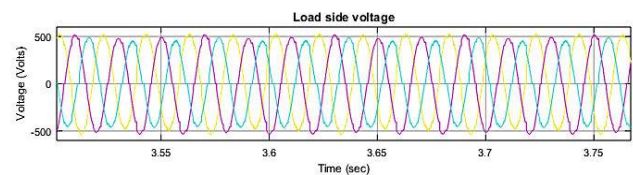

Fig.5.3. Load side voltage (SAPF)

The figure 5.4 showing the load side voltage for the HSAPF, while the load is nonlinear and this better than the SAPF arrangement. Here also the quality of the signal is to be measured by the FFT analysis.

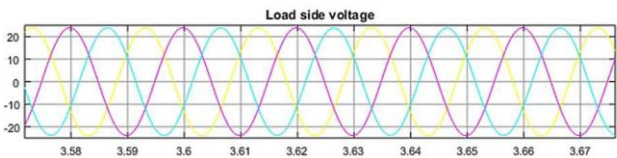

Fig.5.4. Load side voltage (HSAPF)

The source side current is with the harmonics i.e. disturbances exist in the load current shown in figure 5.5, the quality of this current is of SAPF to be measured by the FFT analysis with THD calculation.

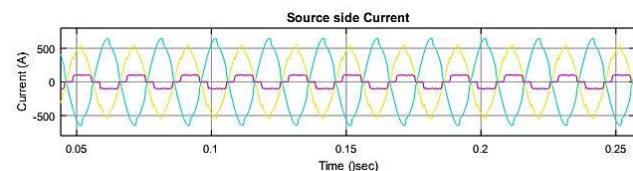

Fig.5.5. Source side current (SAPF)

The source side current is also with the harmonics i.e. disturbances exist in the load current shown in figure 5.6, the quality of this current is in HSAPF. Which is better than the SAPF.

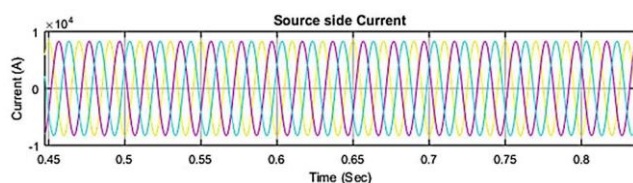

Fig.5.6. Source side current (HSAPF)

The load side current output is shown in figure 5.7, the compensation current which is adjusting according to the compensation requirement for power quality improvement, the waveform showing the quick response of SAPF. But here the profile of current is not so good.

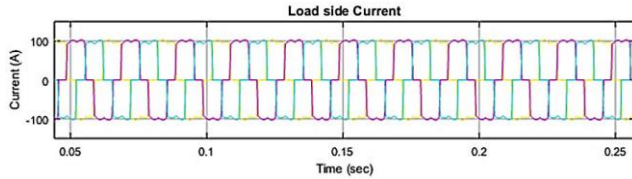

Fig.5.7. Load side current (SAPF)

The load side current output is shown in figure 5.8 the compensation current which is adjusting according to the compensation requirement for power quality improvement, the waveform showing the quick response of HSAPF.

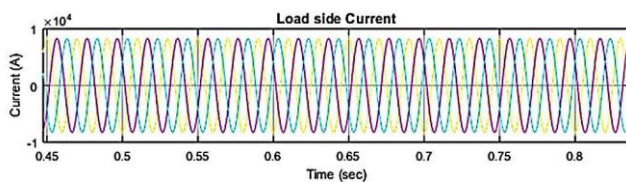

Fig.5.8. Load side current (HSAPF)

The filter compensation current output is shown in figure 5.9 the compensation current which is adjusting according to the compensation requirement for power quality improvement, the waveform showing the quick response of SAPF.

## VI. CONCLUSION & FUTURE WORK

### 6.1 Conclusion

The thesis presents comparative analysis of instantaneous reactive power and dc link voltage PI control algorithms for shunt APF in order to eliminate harmonic frequency present in the AC source current. It has been confirmed that, the performance of the PI controller method is superior as compare to the preceded methods. It is possible to obtain the acceptable THD values for source currents by using the proposed method. The analysis has been verified by the comparative tables presented in the chapter 5. Furthermore, the response of dc link voltage by PI controller is better than instantaneous reactive power technique (IRPT) methods. The constant dc-link voltage enhances the life and performance of capacitor shunted across APF, so use of latter method is more reliable. The algorithms have been simulated to demonstrate the feasibility and effectiveness of the study using MATLAB/SIMULINK. Further, the estimation part is presented which motive is to understand the harmonic estimation. In Future new control algorithms for shunt APF involving the previous control methods and harmonic estimation part can be used for better performance of

SAPF. Different existing evolution or soft techniques are more effective and are using widely in various applications so, it may possible that the performance of the SAPF can be improved significantly.

## REFERENCES

- [1] Alok K. Mishra, Prakash K. Ray “Adaptive fuzzy controlled hybrid shunt active power filter for power quality enhancement” International Journal on Neural Computing and Applications, Springer, 2020.
- [2] Asad Ullah, Inam Ul Hasan Sheikh, Shahzad Arshad, Faisal Saleem “Digital Active Power Filter Controller Design for Current Harmonics in Power System” 16th International Bhurban Conference on Applied Sciences & Technology (IBCAST), IEEE, 2019.
- [3] Shailendra Jain “Control Strategies of Shunt Active Power Filter” A book on Modeling and Control of Power Electronics Converter System for Power Quality Improvements, Elsevier, 2018.
- [4] Soumya K. Das, A.K. Ray “Improvement in Power Quality using Hybrid Power Filters based on RLS Algorithm” International Conference on Alternative Energy in Developing Countries and Emerging Economies (AEDCEE), Elsevier, 2017.
- [5] Dinesh G. Nagotha and M.T. Shah “Hybrid Shunt Active Filter Offering Unity Power Factor and Low THD at Line Side with Reduced Power Rating” International Conference on Power Electronics, Intelligent Control and Energy Systems (ICPEICES), IEEE, 2016.
- [6] Z. Chelli, R. Toufouti “Hysteresis Control for Shunt Active Power Filter under Unbalanced Three-Phase Load Conditions” Journal of Electrical and Computer Engineering, Hindawi Publishing Corporation, 2015.
- [7] Faiza Kaddari, Benyounes Mizari “Comparison of two compensation control strategies for shunt Active Power Filter” International conference on power and control, IEEE, 2014.
- [8] Parag Kanjiya, Bhim Singh, Ambrish Chandra, and Kamal Al-Haddad “SRF Theory Revisited” to Control Self-Supported Dynamic Voltage Restorer (DVR) for Unbalanced and Nonlinear Loads” IEEE, Transactions on Industry Applications, Vol. 49, No. 5, September/October 2013.
- [9] Pablo Acuna, Luis Moran, Marco Rivera, Juan Dixon, and Jose Rodriguez “Improved Active Power Filter Performance for Renewable Power Generation Systems” IEEE transactions on power electronics, vol. 29, no. 2, February 2014.
- [10] Mohammed Qasim, and Vinod Khadkikar “Application of Artificial Neural Networks for Shunt APF Control” IEEE Transactions on Industrial Informatics DOI 10.1109-TII.2014.2322580.
- [11] Bhim Singh, Sabha Raj Arya, Ambrish Chandra, and Kamal Al-Haddad “Implementation of Adaptive Filter in

Distribution Static Compensator” IEEE transactions on industry applications, vol. 50, no. 5, September/October 2014.

- [12] Pradeep Anjana, Vikas Gupta, Harpal Tiwari “Reducing Harmonics in Micro Grid Distribution System Using APF with PI Controller”978-1-4799-3656-4/14, 2014 IEEE.
- [13] S.K. Jain, P. Agrawal and H.O. Gupta “Fuzzy logic-controlled shunt active power filter for power quality improvement” IEEE power electronics, 2002.