

Power Quality Improvement using UPQC: A Review

Vishal Kumar¹, Urmila S. Soni²

¹P.G. Scholar, ²Professor

Department of Electrical & Electronics Engineering, Oriental College Of Technology, Bhopal (M.P.) India

Abstract—The extensive application of power electronic devices induces harmonics in the utility system which generates problems related to the quality of power delivered. Good Power Quality is immense important for both industrial and domestic sectors. Researchers have tried and implemented many useful technology for removing all the voltage and current related harmonic occurrence problems which in turn improves the quality of power delivered to the customers. In general these devices are classified as custom power devices UPQC is one such device which is capable of improving power quality by eliminating source as well as load harmonics. This paper presents a review on power quality improvement by employing Unified Power Quality Conditioner.

Index Terms—Unified power quality conditioner (UPQC), Power quality, power electronic converters, dual control strategy, harmonic compensation, voltage sag and swell compensation.

I. INTRODUCTION

Now a-days non-linear loads are exploited extremely and we are largely dependent on it. Non-linear loads are televisions, arc furnaces, printing and fax machines, microwave ovens, rectifiers, inverters, electronic gadgets, speed drives, AC, etc. All these non-linear loads introduce harmonics in the lines. The stability of any electrical device is largely governed by the supply voltage and current waveforms. If the fundamental waveform is sinusoidal, and its

Harmonics are sinusoidal too then these harmonics occurs in integral multiples of the fundamental waveform consequently supplied power is deteriorate. Due to these harmonic distortion generated by nonlinear loads several problems are caused in the appliances used in our purpose like: overheating of motor, increase in losses, permanent damage of equipment is the worst case, high error in meter reading, etc. Hence mitigation of harmonics both loads side or source side is a big challenge for a power engineer. Due to the harmonics introduction in the

Lines by the nonlinear loads other problems of are generated

such as voltage swell, voltage sag, flicker occurring in voltage, etc. consequently efficiency of power supply degrades.

In past, passive filters using tuned LC components were

in very much use to improve the quality of power by removing voltage and current harmonics. But its use is limited now a days since they have high cost, resonance, large size. The above mentioned problems can be resolved by the use of

Active power filter (APF) which has been in trend now a days.

Numerous topologies for the APF [1] – [17], shunt [18]– [24], series [25] and hybrid active power filters (APFs) [26] are available in literature which has been classified in Figure 1.

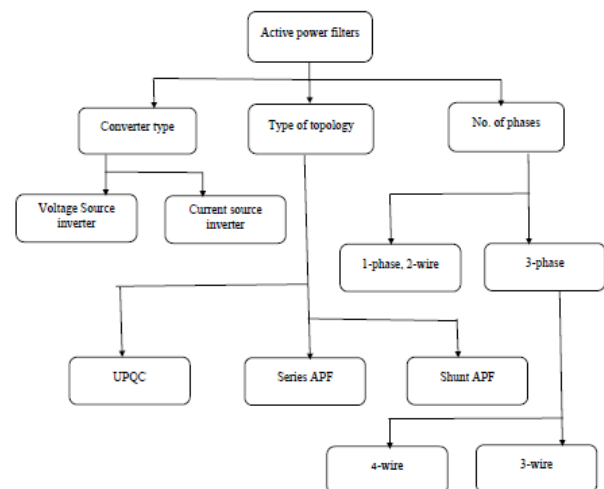

Figure-1 Classification of Active power filters.

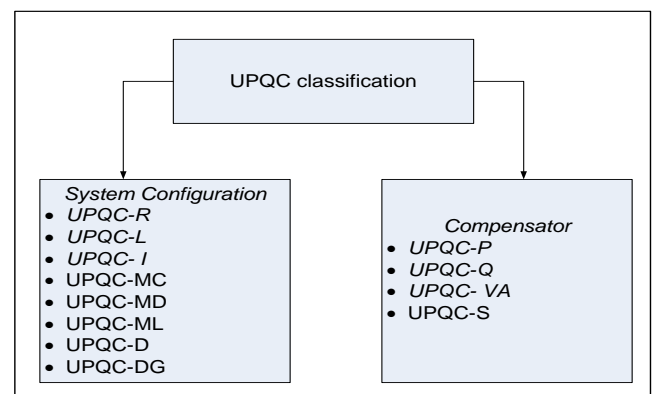

Figure 2 Classification of UPQC

UPQC-R	Right shunt UPQC
UPQC-L	Left shunt UPQC
UPQC-I	Interline UPQC
UPQC-MC	Multi converter UPQC
UPQC-MD	Modular UPQC
UPQC-ML	Multi-level UPQC
UPQC-D	Distributed UPQC
UPQC-DG	Distributed generator integrated with UPQC
UPQC-P	Active power controlled UPQC
UPQC-R	Reactive power controlled UPQC
UPQC-V _{Amin}	Minimum VA loading in UPQC
UPQC-S	UPQC mitigates both active power and reactive power

Table-1 Nomenclature for various types of UPQC

II. UNIFIED POWER QUALITY CONDITIONER

In general series and shunt APF are in use. Combining both series APF & shunt APF custom power device known as UPQC can be designed. UPQC is capable of eliminating both the voltage and current based distortions simultaneously.

A Shunt APF eliminates all kind of current problems like current harmonic compensation, reactive power compensation, power factor enhancement. A Series APF compensates voltage dip/rise so that voltage at load side is perfectly regulated. The Shunt APF is connected in parallel with transmission line and series APF is connected in series with transmission line. UPQC is formed by combining both series APF and shunt APF connected back to back on DC side.

In this controlling techniques used is hysteresis band controller using “p-q theory” for shunt APF and hysteresis band controller using Park’s transformation or dq0 transformation for series APF. Figure 2 presents the general structure of UPQC which comprises of source supplied by and renewable energy source or by the utility source two back-back inverters may be current source inverters, voltage source inverters, Multi-level inverters etc. coupled through dc-link voltage. One inverter is connected in parallel through shunt impedance and is connected in series with help of series impedance. One inverter is connected source side another inverter is connected load side. Load may be linear, non-linear, single phase, three phase etc.

The basic topology has been evolved by researchers in numerous topologies to obtain the desired application. The classification various topologies of UPQC proposed in the literature has been classified in Figure 2.

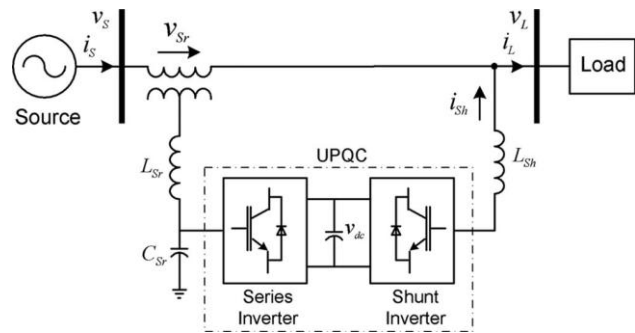

Fig-2 Basic structure of UPQC.

III. TOPOLOGIES OF UPQC

The control of dc-link voltage assumes a vital part in accomplishing the coveted UPQC execution. Amid the framework dynamic conditions, for instance, sudden load change, voltage droop, the dc-connect input controller ought to react as quick as conceivable to reestablish the dc-interface voltage at set reference esteem, with least deferral and additionally bring down overshoot. In literature various control strategies are available to tune the dc-link voltage and to achieve the desired controls for PQ issues which has been discussed in brief here.

UPQC-R and UPQC-L; Right and Left shunt UPQC, since UPQC consist of two converters either can be shunted, so when right converter is shunted its termed as UPQC-R as shown in Fig-2 and when left converter is shunted it is termed as UPQC-L. As shown in Fig-3. In UPQC-R, the current(s) that move through arrangement transformer is (are) mostly sinusoidal independent to the idea of load current on the framework (given that the shunt inverter repays current music, responsive current, unbalance, and so forth, successfully). In this way, UPQC-R gives a superior general UPQC execution contrast with UPQC-L. The UPQC-L structure is here and there utilized as a part of unique cases, for instance to avoid the interference between the shunt inverter and passive filters.

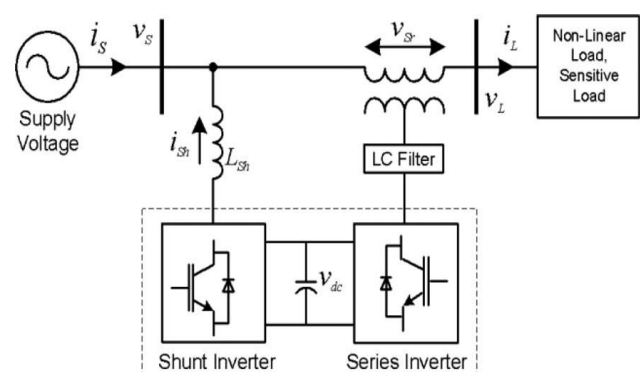

Fig-2 UPQC-L

1) *UPQC-I*; When the two inverters of the UPQC are interlinked between twofeeders the resulting configuration is known as interline UPQC (UPQC-I). Among the two inverters one is connected in series and another in parallel with the two feeders of the distribution network. This

configuration assists the control of voltage of both the feeders simultaneously.

Also UPQC-I is capable to control the flow of active power among the feeders. Fig-4

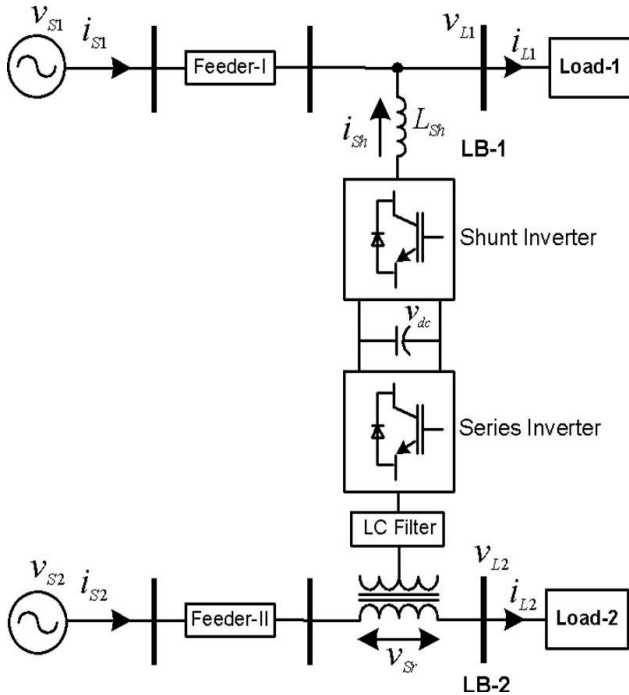

Fig-4 UPQC-I

2) *UPQC-MC*; third converter is furthermore connected in the existing UPQC configuration to support the Dc bus voltage is known as UPQC-MC (Fig-5). The third converter can either be connected in series or in parallel with one of the converter and with the feeder.

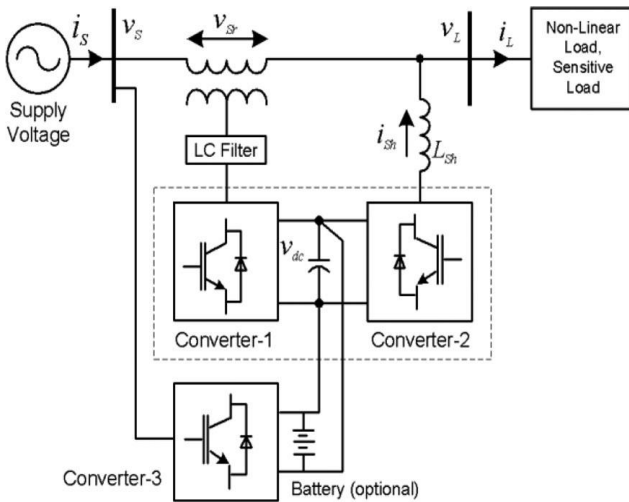

Fig-5 UPQC-MC

3) *UPQC-MD*; the cascaded H-Bridge MLI is used as the two converter to design modular UPQC topology as shown in Fig-6. In [27] and [28], the H-bridge modules for shunt part of UPQC are connected in series through a multi-winding transformer, while the H-bridges in the series part are directly connected in series and inserted in the distribution line without a series injection transformer.

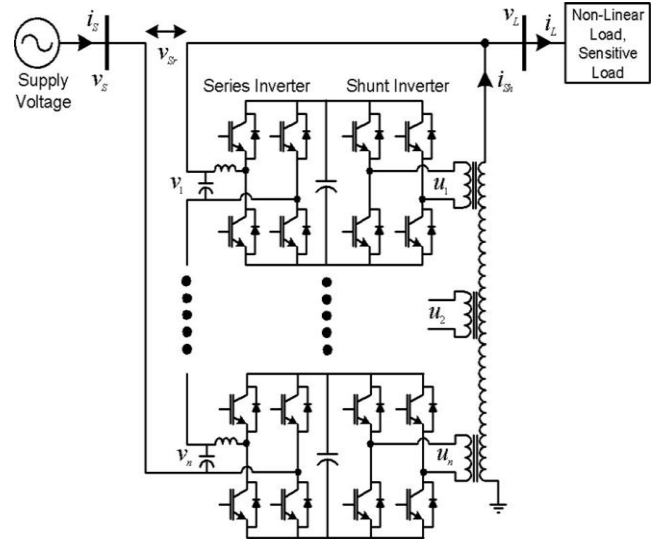

Fig-6 UPQC-MD

4) *UPQC-ML*; to design UPQC-ML neutral point clamped MLI is used in place of series and shunt inverter as shown in Fig-7.

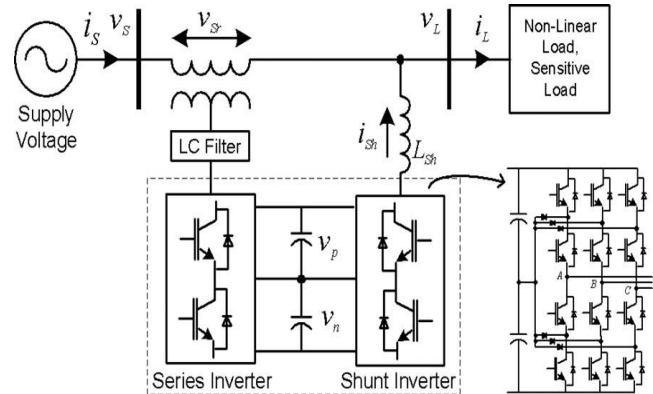

Fig-7 UPQC-ML designed using Neutral point clamped MLI

5) *UPQC-D*; the UPQC used to resolve PQ issues in three phase three wire and three phase four wire distribution network is called as UPQC-D as shown in fig-8. A 3P4W distribution system is generally realized by providing a neutral conductor along with the three power lines from substation or by utilizing a delta-star transformer at the distribution level [29-30].

6) *UPQC-DG*; UPQC employed to integrate one or more distributed generations like solar, wind, etc. with the utility grid is called UPQC-DG. The DG power can be regulated and managed through UPQC to supply to the loads connected to the PCC in addition to the voltage and current power quality problem compensation [31-36]. This topology of UPQC is very popular among the researchers of renewable energy resources and being widely used to mitigate the PQ issues like current harmonics, voltage flickers, real and reactive power compensation, etc. Fig-9 presents the topology for UPQC-DG.

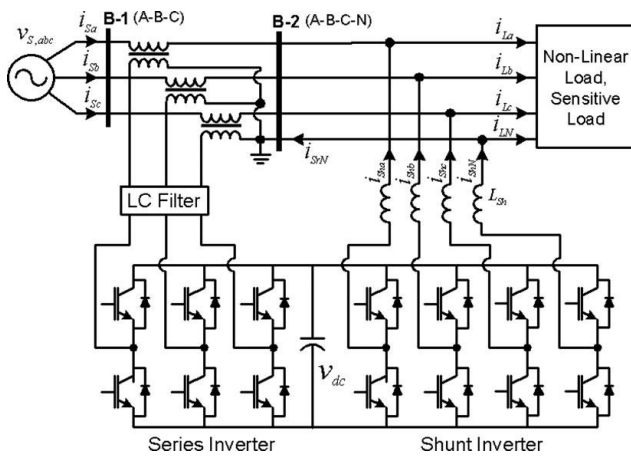

Fig-8 UPQC-D

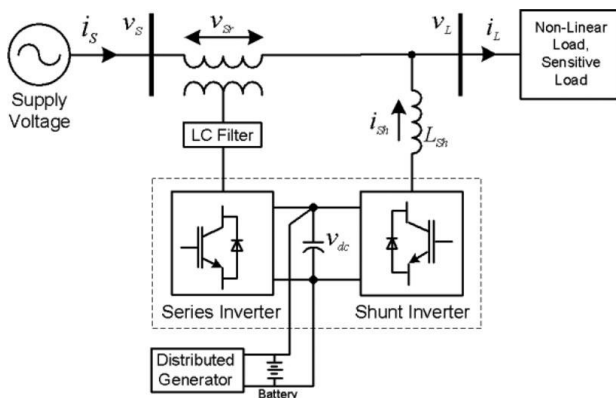

Fig-9 UPQC-DG

IV. CONCLUSION

Degradation of power quality due to increased penetration of DERs and power electronic devices concern to improve the quality is also increasing to meet the grid code. Various custom power devices are available literature to enhance the quality of power or to mitigate PQ issues. This paper presents the review on UPQC to mitigate PQ issues. Available topologies its characteristics and classification of UPQC is presented.

REFERENCES

[1] H. Akagi, "Trends in active line conditioner", IEEE Transactions On Power Electronics, vol.9, no.3, 1994.

[2] H. Fujita and H. Akagi, "The Unified Power Quality Conditioner : The integration of series and shunt active filters" IEEE Transactions on Power Electronics, vol.13, no.2 March 1998.

[3] N. Hingorani, "Introducing Custom Power," IEEE Spectrum, Vol.32, Issue: 6, June 1995, pp 41-48.

[4] H. Awad, M. H.J Bollen, "Power Electronics for Power Quality Improvements," IEEE Symposium on Industrial Electronics, 2003, vol.2, pp. 1129-1136

[5] Bhim Singh, Kamal Al-Haddad and Amrish Chandra , "A Review of Active Filters for Power Quality Improvement" IEEE Trans. on Industrial Electronics, Vol.46, No.5, oct. 1999, pp.960-971..

[6] H. Akagi, Y. Kanazawa, A. Nabae , "Generalized Theory of the Instantaneous Reactive Power in Three Phase Circuits", in Proceedings. IPEC-Tokyo'83 International Conf. Power Electronics, Tokyo.,pp.1375-1386.

[7] H. Akagi, Y. Kanazawa, and A. Nabae, "Instantaneous reactive power compensators comprising switching devices without energy storage components," IEEE Transactions Industry Applications, vol. IA-20, pp. 625-30, May/June 1984.

[8] E. H. Watanabe, R. M. Stephen, and M. Arcdes, "New concept of instantaneous active and reactive powers in electric systems with generic load," IEEE Transactions. on Power Delivery, vol.8, April 1993, pp 697-703.

[9] Rosli Omar, NasrudinAbd Rahim, Marizansulaiman "Modeling and Simulation for voltage sags/swells mitigation using dynamic voltage restorer (DVR)" IEEE journal on Power Electronics Drives and Energy System.

[10] M. A. Chaudhari and Chandraprakash, "Three-Phase Series Active Power Filter as Power Quality Conditioner," IEEE International Conference on Power Electronics, Drives and Energy Systems, Dec. 2012, pp 1-6.S. Moran, "A line voltage regulator/conditioner for harmonic-sensitiveload isolation," in Proc. Ind. Appl. Soc. Annu. Meet. Conf., Oct. 1-5,1989, pp. 947-951.

[11] F. Kamran and T. G. Habetler, "Combined deadbeat control of a seriesparallelconverter combination used as a universal power filter," in Proc.Power Electron. Spec. Conf., Jun. 18-22, 1995, pp. 196-201.2294 IEEE TRANSACTIONS ON POWER ELECTRONICS, VOL. 27, NO. 5, MAY 2012

[12] S. Muthu and J. M. S. Kim, "Steady-state operating characteristics of unified active power filters," in Proc. Appl. Power Electron. Conf., Feb.23-27, 1997, pp. 199-205.

[13] H. Fujita and H. Akagi, "The unified power quality conditioner: The integrationof series and shunt-active filters," IEEE Trans. Power Electron.,vol. 13, no. 2, pp. 315-322, Mar. 1998.

[14] B. N. Singh, A. Chandra, K. Al-Haddad, and B. Singh, "Fuzzy controlalgorithm for universal active filter," in Proc. Power Quality Conf., Oct.14-18, 1998, pp. 73-80.

[15] M. Aredes,K.Heumann, and E.H.Watanabe, "An universal active powerline conditioner," IEEE Trans. Power Del., vol. 13, no. 2, pp. 545-551,Apr. 1998.

[16] M. C. Wong, C. J. Zhan, Y. D. Han, and L. B. Zhao, "A unified approachfor distribution system conditioning: Distribution system unifiedconditioner (DS-UniCon)," in Proc. Power Eng. Soc. Winter Meet., Jan.23-27, 2000, pp. 2757-2762.

[17] M. Hu and H. Chen, "Modeling and controlling of unified power qualityconditioner," in Proc. Adv. Power Syst. Control, OperationManage.,Oct.30-Nov. 1, 2000, pp. 431-435.

[18] D. Graovac, V. Katic, and A. Rufer, "Power quality compensation usinguniversal power quality conditioning system," IEEE Power Eng. Rev.,vol. 20, no. 12, pp. 58-60, Dec. 2000.

- [19] Y. Chen, X. Zha, J. Wang, H. Liu, J. Sun, and H. Tang, "Unified power quality conditioner (UPQC): The theory, modeling and application," in Proc. Int. Conf. Power Syst. Technol., 2000, pp. 1329–1333.
- [20] S. Chen and G. Joos, "Rating issues of unified power quality conditioners for load bus voltage control in distribution systems," in Proc. Power Eng. Soc. Winter Meet., 28 Jan.–1 Feb., 2001, pp. 944–949.
- [21] S. Chen and G. Joos, "A unified series–parallel deadbeat control technique for an active power quality conditioner with full digital implementation," in Proc. IEEE 36th Ind. Appl. Soc. Annu. Meet. Ind. Appl. Conf., 30 Sep.–4 Oct., 2001, pp. 172–178.
- [22] M. Basu, S. P. Das, and G. K. Dubey, "Experimental investigation of performance of a single phase UPQC for voltage sensitive and nonlinear loads," in Proc. 4th IEEE Int. Conf. Power Electron. Drive Syst., Oct. 22–25, 2001, pp. 218–222.
- [23] A. Elnady, A. Goauda, and M. M. A. Salama, "Unified power quality conditioner with a novel control algorithm based on wavelet transform," in Proc. Can. Conf. Electr. Comput. Eng., 2001, pp. 1041–1045.
- [24] A. Elnady and M. M. A. Salama, "New functionalities of an adaptive unified power quality conditioner," in Proc. Power Eng. Soc. Summer Meet., 2001, pp. 295–300.
- [25] B. S. Chae, W. C. Lee, D. S. Hyun, and T. K. Lee, "An overcurrent protection scheme for series active compensators," in Proc. 27th Annu. Conf. IEEE Ind. Electron. Soc., 2001, pp. 1509–1514.
- [26] E. H. Watanabe and M. Aredes, "Power quality considerations on shunt/series current and voltage conditioners," in Proc. 10th Int. Conf. Harmonics Quality Power, Oct. 6–9, 2002, pp. 595–600.
- [27] A. Pievatolo, E. Tironi, I. Valade, and G. Ubezio, "UPQC reliability analysis," in Proc. 10th Int. Conf. Harmonics Quality Power, Oct. 6–9, 2002, pp. 390–397.
- [28] P. Rodriguez, L. Sainz, and J. Bergas, "Synchronous double reference frame PLL applied to a unified power quality conditioner," in Proc. 10th Int. Conf. Harmonics Quality Power, Oct. 6–9, 2002, pp. 614–619.
- [29] J. Prieto, P. Salmeron, J. R. Vazquez, and J. Alcantara, "A series–parallel configuration of active power filters for VAR and harmonic compensation," in Proc. IEEE 28th Annu. Conf. Ind. Electron. Soc., Nov. 5–8, 2002, pp. 2945–2950.
- [30] A. Elnady, W. El-khattam, and M. M. A. Salama, "Mitigation of AC arc furnace voltage flicker using the unified power quality conditioner," in Proc. Power Eng. Soc. Winter Meet., 2002, pp. 735–739.
- [31] M. T. Haque, T. Ise, and S. H. Hosseini, "A novel control strategy for unified power quality conditioner (UPQC)," in Proc. Power Electron. Spec. Conf., 2002, vol. 1, pp. 94–98.
- [32] G. Jianjun, X. Dianguo, L. Hankui, and G. Maozhong, "Unified power quality conditioner (UPQC): The principle, control and application," in Proc. Power Convers. Conf., 2002, pp. 80–85.
- [33] L. H. Tey, P. L. So, and Y. C. Chu, "Neural network-controlled unified power quality conditioner for system harmonics compensation," in Proc. IEEE/PES Transmiss. Distrib. Conf. Exhib., 2002, pp. 1038–1043.
- [34] R. Faranda and I. Valade, "UPQC compensation strategy and design aimed at reducing losses," in Proc. IEEE Int. Symp. Ind. Electron., 2002, pp. 1264–1270.
- [35] L. F. C. Monteiro, M. Aredes, and J. A. Moor Neto, "A control strategy for unified power quality conditioner," in Proc. Int. Symp. Ind. Electron., Jun. 9–11, 2003, pp. 391–396.
- [36] M. Correa, S. Chakraborty, G. Simoes, and A. Farret, "A single phase high frequency AC microgrid with a unified power quality conditioner," in Proc. IEEE Int. Symp. Ind. Electron., Jun. 9–11, 2003, pp. 956–962.
- [37] J. Liu, Y. He, Y. Ye, and X. Wang, "A unified scheme and respective algorithms for the control of DC-linked double converters in a universal power quality controller," in Proc. Power Electron. Spec. Conf., Jun. 15–19, 2003, pp. 327–332.