

Enhancement of Power and Stability using SSSC with Fuzzy Compensator in A Power System

Patel Pinkeshkumar¹, Hitesh Lade²

¹M-Tech Research Scholar, ²Head of Department

Abstract

In recent years, power demand has increased substantially while the expansion of power generation and transmission has been severely limited due to limited resources and green limitations. As a result, some transmission lines are heavily loaded and the system stability becomes a power transfer-limiting factor. Flexible AC transmission systems (FACTS) controllers have been mainly used for solving various power system steady state control problems. In this work an optimized fuzzy logic based static synchronous series compensator is designed in place of a PI controlling technique and simulations are carried on a long transmission line by varying the load step by step and results are compared with and without fuzzy logic controller. The proposed fuzzy logic controller improves power system transient stability and system damping. Fuzzy logic controller works according to system behavior as Controller input parameters are carefully considered to provide effective damping for power system. The capacity of each controller is obtained based on simulation results of the fuzzy logic procedure. Results carried out by simulation indicate that this controller can improve stability margin of the system in the case of transient stability and provide considerable damping of power oscillation.

Keywords

Fuzzy Logic Controller, SSSC, Transient Stability, Oscillation damping.

1. Introduction

Transient stability analysis is considered when the power system is confronted with large disturbances. Sudden changes in load, generation or transmission system configuration due to fault or switching are examples of large instability. Power system should gain its synchronism during and after all these kind of disturbances. Therefore transient stability is an important security criterion in power systems design. Different methods have been used for transient stability analysis in power systems. The utilities must need to operate their power transmission system more effectively, rising their utilization degree. Decreasing the useful reactance of lines by series compensation is a direct approach to increase transmission capacity. However, power transfer capacity of long transmission line is limited by stability considerations. But the advent of fast acting FACTS devices allows for fast and vernier control of series compensation

using thyristor control series capacitor (TCSC) and static synchronous series compensator (SSSC). SSSC is based on voltage source converter (VSC).

2. System Model

Schematic diagram is shown in fig 1.

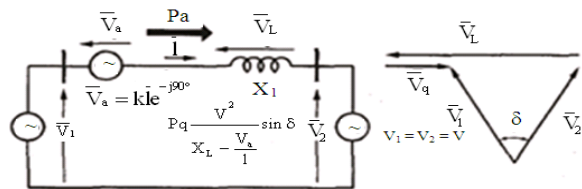

Fig.1. Basic model of the series compensation with a voltage source

Flexible AC Transmission System (FACTS) devices are used to control power flow along transmission lines and improve power system stability SSSC is one of the series FACTS devices that are usually used for voltage regulation and also

used to improve power system stability by injecting or absorbing reactive power. This function of SSSC needs some more supplementary input signals, several controllers have been used to perform this control strategy such as conventional PI controller. This paper investigates the static synchronous series compensator (SSSC) FACTS controller in terms of transient stability improvement and power system stability and performance. Here this paper is divided into six sections. In the first section a system model is described of long transmission line taken under consideration. in the second section PI controlling based SSSC model is elaborated in details. In the third section fuzzy logic controller with rule bases replaces the PI controller is described and also complete fuzzification with rule bases are discussed. In the fourth section results are compared between PI controlled SSSC and fuzzy based SSSC which are observed in the scope of matlab and readings are compared in Photoshop manager to review waveform comparison clearly. in the fifth section the work is concluded were it is proved that power system stability performance and damping is improved using fuzzy logic control. Finally in the last section references are given.

3.1 CASE STUDY OF SSSC

A 230 kV ,100 MVA source is taken for a long transmission line of 800 km. the line resistance per unit length is considered as [0.01273 0.3864] ohms/km [N*N matrix] or [R1 R0 R0m] in per unit, the line inductance per unit length is [0.9337e-3 4.1264e-3] H/km [N*N matrix] or [L1 L0 L0m] and the line capacitance per unit length is [12.74e-9 7.751e-9] F/km [N*N matrix] or [C1 C0 C0m] for each 200 km length. In this long transmission line parallel R-L-C load is connected which is introduced in different steps as no load, half load and full load. SSSC is introduced in series in the middle of the line as the most nominal place in the T model of installation strategy. The complete model is described in fig 2.

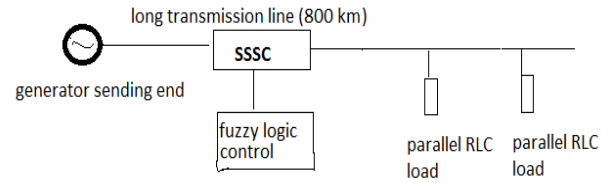

Fig.2. Block diagram of the model considered

To achieve real and reactive power flow control, it is necessary to inject series voltage of the appropriate magnitude and angle were the injected voltage can be split into two components which are in phase and in quadrature with the line current. The real power is controlled using the reactive voltage and the reactive power is controlled using the real voltage. The real and reactive power reference is obtained from the steady state load flow needs. The real power reference can be considered to improve damping and transient stability.

3.2 Control scheme for SSSC

The main function of the SSSC is to dynamically control the power flow over the transmission network. The existing control schemes explained were based on the line impedance control mode in which the SSSC compensating voltage is derived by multiplying the current amplitude with the desired compensating reactance X_{qref} . Even it is complicated to assume X_{qref} under varying network contingencies, the voltage control method is considered in the existing scheme. This controller is made advanced to operate the SSSC in the automatic power flow. In the automatic power flow control method, the specified inputs to the controller are reference powers P and Q . These are made stable in the transmission line despite method changes. Using dq transformation the line voltage and the current are converted to corresponding d and q axis components. The power references are converted to current references using the Eq. i and ii. From the current references the sigma angle is calculated and then the firing pulses are generated.

$$I_{dref} = (P \times V_d + Q \times V_q) / (V_d^2 + V_q^2) \quad [i]$$

$$I_{dref} = (P \times V_q + Q \times V_d) / d(V^2 + V_q^2) \quad [ii]$$

3.3 SSSC dynamics

The transfer function of static synchronous series compensator based controller is:

$$U_{SSSC} = K_S \left(\frac{sT_W}{1 + sT_W} \right) \left(\frac{1 + sT_{1S}}{1 + sT_{2S}} \right) \left(\frac{1 + sT_{3S}}{1 + sT_{4S}} \right) y,$$

Where, USSSC and y are the output and input signals of the SSSC-based controller respectively. During steady state conditions ΔV_q and V_{qref} are constant. In dynamic conditions the series injected voltage V_q is modulated to damp system oscillations. The effectual V_q in dynamic conditions is given by:

$$V_q = V_{qref} + \Delta V_q.$$

3.4 Fuzzy Logic Control

Fuzzy control systems are rule-based systems in which a set of so-called fuzzy rules represent a control decision mechanism to adjust the effects of certain system stimuli. The importance of fuzzy control systems is to replace a skilled human operator with a fuzzy rule-based system. The FLC provides an algorithm which can convert the linguistic control strategy based on expert knowledge into an automatic control approach. The FLC involves four main stages: inference mechanism, fuzzification, rule base, and defuzzification (Sivanandam and Deepa, 2009). The structure of the fuzzy logic controller is shown in fig 3.

The error and change in error are taken as the inputs to the fuzzifier. Here the error is between the line voltage and the reference voltage (i.e V_q and V_{ref}) and the change in error is taken by subtracting two consecutive error values by providing a unit step delay and giving the second input to the fuzzifier as shown in the figure. Triangular membership functions are used for the inputs & the output.

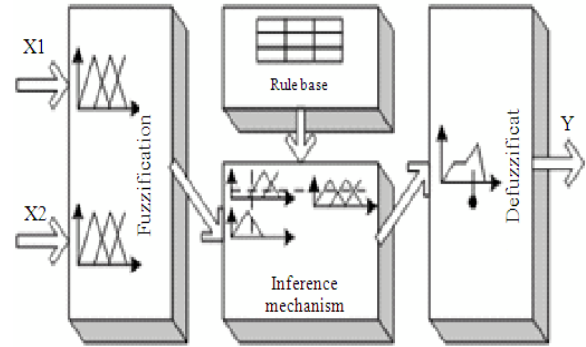

Fig.3. The structure of the fuzzy logic controller

The universe of discourse for both the inputs is divided into seven partitions (NL - Negative Large, NM - Negative Medium, NS - Negative Small, Z - Zero, PS - Positive Small, PM - Positive Medium, PL - Positive Large). The o/p is the voltage & again the universe of discourse is divided into seven partitions. Fuzzy rules are if then rules were these are specified by max -min operator functions the fuzzy rules taken here are of the form:

- (1) If error is large negative (LN), AND change in error is large negative (LN); THEN output (u) is large positive (LP).
- (2) For N linguistic variables for each of error and change in error there are N^2 possible combinations resulting into any of M values for the decision variable u. All numbers of variable inputs, called states, and the resulting control are then arranged in a $N^2 \times M$ 'fuzzy relationship matrix' (FRM).
- (3) The membership values for the condition part of each rule are calculated from the composition rule as Follows:

$$\mu(X_i) = \mu(e \text{ is LN, and } \Delta e \text{ is LN}) = \min [\mu(\Delta \omega \text{ is LN}), \mu(\Delta \omega \text{ is LN})]; \text{ where } i=1, 2, \dots, N^2 \text{ Here, } X_i \text{ is the } i\text{-th value of the } N^2 \text{ possible states (in-put-combinations) in the FRM.}$$

- (4) The membership values for the output characterized by the M linguistic variables are then obtained from the intersection of the N^2 values of membership function $\mu(x)$ with the corresponding values of each of the decision variables in the Fuzzy Matrix. For example, for the decision LN $\in M$ and for state ij , we obtain,

$$\mu u(X_i, LN) = \min[\mu(X_i, LN), \mu u(X_i, LN)]$$

Where $i=1, 2, N2$ the final value of the stabilizer output 'LP' can be evaluated as the union of all the outputs given by the relationship membership values for the other $M-1$ linguistic variables are generated in a similar manner.

(5) The fuzzy outputs obtain crisp u . The famous methods of defuzzification are the centroid and the weighted average methods. Using the centroid method, the output of the FLC is then written as

$$u = \frac{\sum_{i=1}^M \mu_u(A_i) * A_i}{\sum_{i=1}^M \mu_u(A_i)}$$

$$u = \frac{\sum_{i=1}^M (\mu_u(A_i) * \text{threshold value of } A_i)}{\sum_{i=1}^M \mu_u(A_i)}$$

(6) A set of decision rules relating the inputs to the output are compiled and stored in the memory in the form of a 'result table'. The rules are of the form:

Table-1: Decision rules established for fuzzy controller

	NL	NM	NS	Z	PS	PM	PL
NS	PS	PL	PL	PS	NM	NS	NM
NM	PM	PL	PL	PM	Z	Z	Z
NL	PL	PL	PL	PL	Z	Z	Z
Z	PS	PM	PL	Z	NS	NM	NL
PS	PS	PS	NM	NS	NS	NL	NL
PM	Z	Z	Z	NM	NM	NL	NL
PL	Z	Z	Z	NL	NL	NL	NL

4. SSSC Phasor Control Model

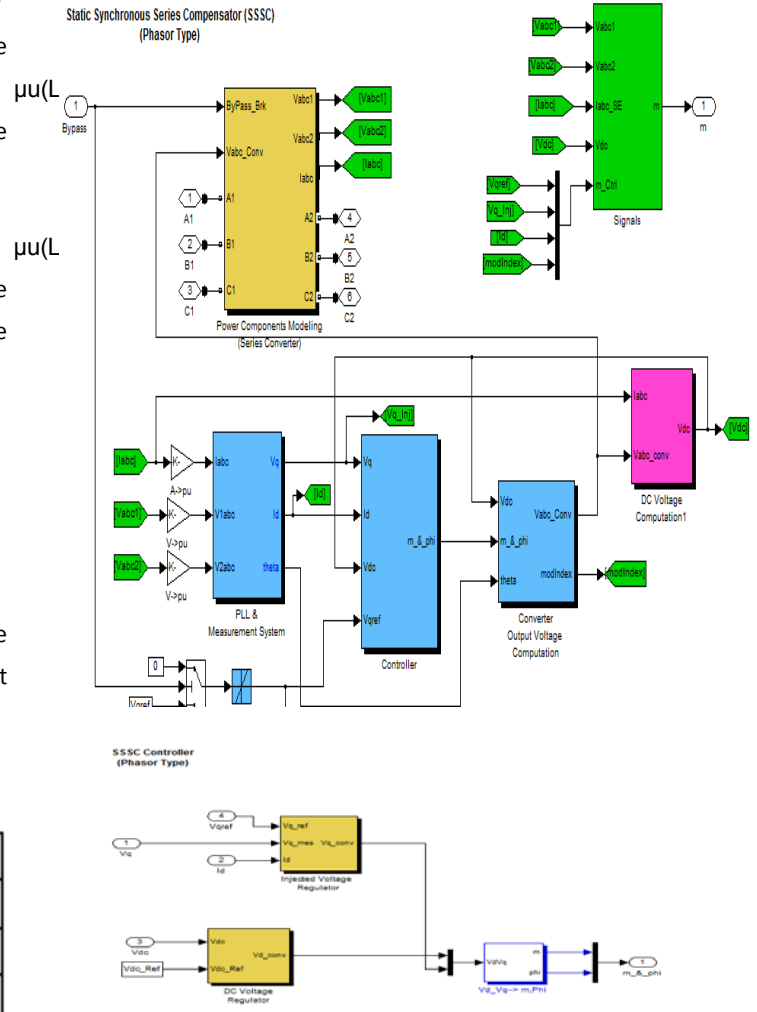

Fig.4. SSSC phasor control model

Injected voltage V_q and V_{q_ref} is measured in the SSSC phasor control as shown in fig. 4. And the current I_d and V_{q_conv} is modulated by the PI control shown in fig. 5. Here the higher order terms containing error and change in error are neglected in PI control. In our proposed controller with fuzzy logic the error and change in error terms are fed as input in the replacement of fuzzy logic controller as shown in fig 6. The bus voltage needed is controlled by following equation which are locally available which can easily calculate our real voltage $eP(pq)$:

$$V(b) = \sqrt{(VD(b))^2 + (VQ(b))^2}$$

$$V(b) = \sqrt{(VR(a) + eR(pq))^2 + (VP(a) + eP(pq))^2}$$

$$VR(a) = VD(a) * \cos(\theta^1) - VQ(a) * \sin(\theta^1)$$

$$VP(a) = VD(a) * \sin(\theta^1) + VQ(a) * \cos(\theta^1)$$

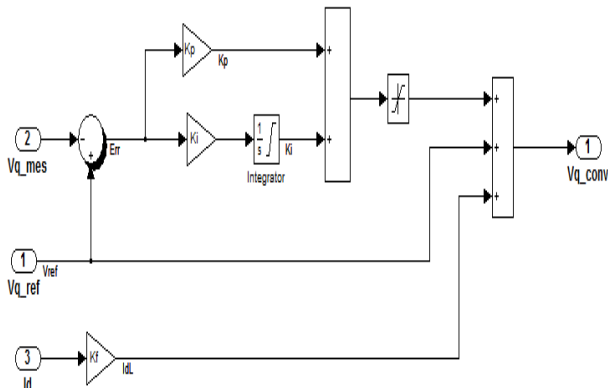

Fig.5. PI control based injected voltage regulator of sssc control

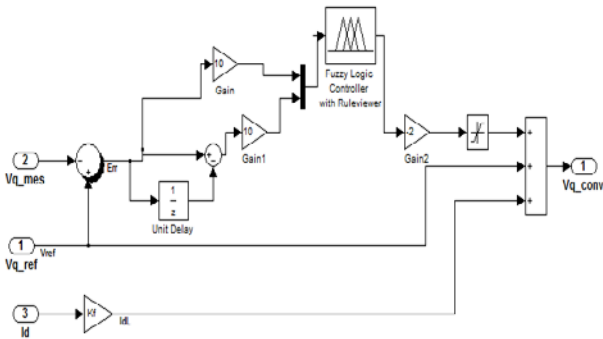

Fig -6: Fuzzy logic replacement in injected voltage regulator of SSSC control in place of PI control

5. Results of case studies

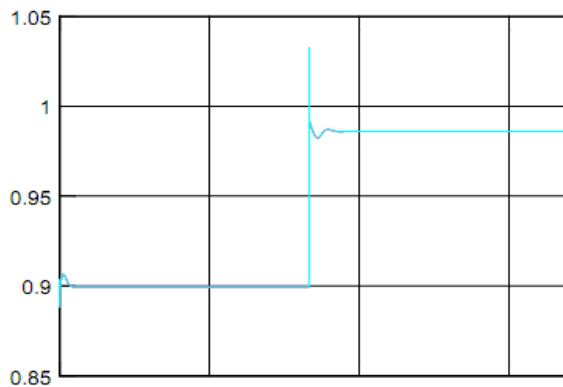

Fig.7. Line voltage with PI control

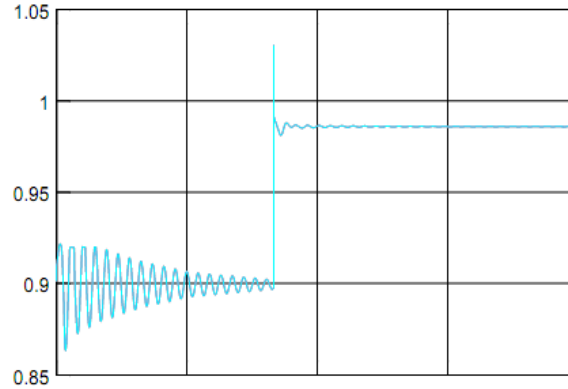

Fig.8. Line voltage with fuzzy logic control

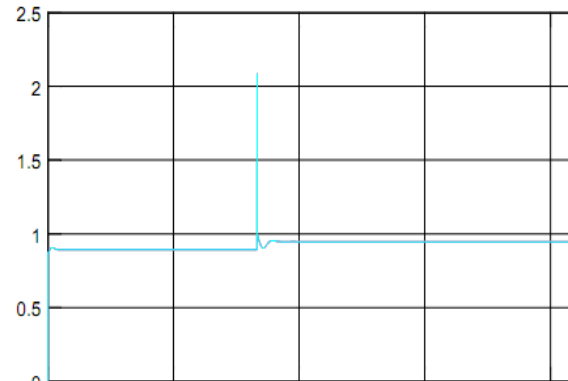

Fig.9. SSSC D.C voltage with PI control

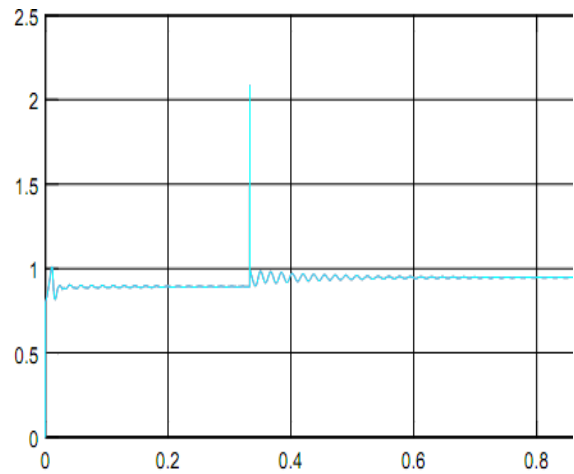

Fig.10. SSSC D.C voltage with fuzzy logic control

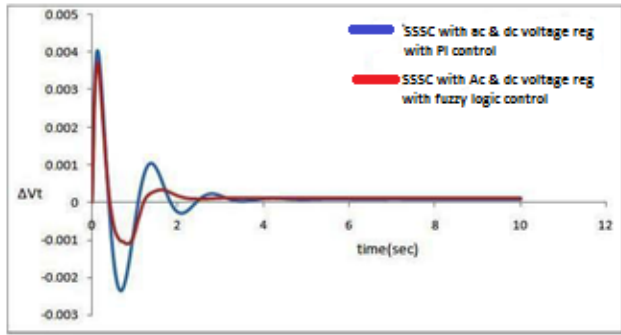

Fig.11. Voltage regulation comparison and transient analysis

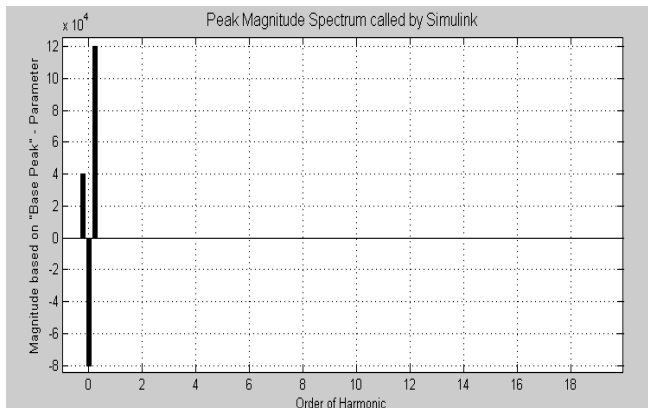

Fig.11. FET Analysis

Result analysis

[I] Error can be determined in fig 8 compared to fig 7 and hence bandwidth can be reduced and hence damping ratio increases which increases the gain K of the system.

[II] Sensitivity increases as line voltage increases and it is compared in both figures 7 & 8 and hence static and dynamic security in power system becomes more sensitive to fault cure. Also it can be seen that the changed system is more sensitive to disturbances (even noise disturbances).

[III] Settling time is improved from 3.8 sec to 2.4 sec, also rise time and overshoots are minimized reducing the transient time and making response of system fast as seen in fig 11.

[IV] Per unit Voltage regulation is improved.

[V] Necessary oscillation's are seen in the proposed control system.

6. Conclusion

In this paper, a fuzzy logic controller is proposed to control SSSC for improving power system transient and steady state stability and system damping. Fuzzy logic controller works according to system performance. Controller i/p parameters are carefully chosen to provide considerable damping for power system. The value of each controller is obtained based on simulation results of the fuzzy logic process. Results of simulation indicate that this controller can improve stability margin of the system in the case of transient and steady state stability and provide considerable damping of power oscillation and also increases the gain of system by reducing the bandwidth.

7. Future Scopes

Work can be carried out now by this controller in the improvement of static and dynamic security system and results can be obtained also the fuzzy logic controller can be optimized using neural networks and a neuro fuzzy logic control can be formed in future.

References

- [1] Panda, S., 2010. Modelling, simulation and optimal tuning of SSSC-based controller in a multi machine power system. *World J. Model. Simulation*, 6: 110-121.
- [2] Pratumswan, P., S. Thongchai and S. Tansriwong, 2010. A hybrid of fuzzy and proportional-integral-derivative controller for electro-hydraulic position servo system. *Energy Res. J.*, 1:62-67. DOI:10.3844/erjsp.2010.62.67.
- [3] Ustun, T.S. and S. Mekhilef, 2010, Effects of a Static Synchronous Series Compensator (SSSC) based on a soft switching 48-pulse pwm inverter on the power demand from the grid. *J. Power Elect.*, 10: 85-90.
- [4] H.A.Toliat, J. Sadeh and R. Ghazi, "Design of augmented fuzzy logic power system stabilizers to enhance power system stability," *IEEE Trans. Energy Conversion*, vol. 11, No.1, pp. 97-103, 1996.
- [5] K.R.Padiyar and A.M. Kulkarni, "Analysis and design of voltage control of static condenser", *IEEE conference on power electronics, drives and energy systems for industrial growth 1*, pp 393-398, 1996.
- [6] Z.Yao, P.Kesimar, N.lacchivin and V.rajagopalan, "Nonlinear control for STATCOM based on differential algebra", *IEEE specialist conference 1*, pp 323-334, 1998.
- [7] H.F.Wang and F.Li, "Design of STATCOM multivariable sampled regulator", *IEEE conference on electric utility deregulation and power technologies*, April 2000.

- [8] B.K.Keshavan and M.Prabhu, "Damping of sub synchronous oscillations using STATCOM – A FACTS Device", Transmission and Distribution conference and exposition, 2001 IEEE/PES volume 1, 28 Oct-2 Nov. 2001, page(s) 1-7. vol.1.
- [9] Y.Ni and L.O.Mak, "Fuzzy logic damping controller for FACTS devices in interconnected power systems". Proceedings of IEEE international symposium as circuits and systems, vol. 5, pp 591-594, 1999.
- [10] D.Harikrishna, R.S.Dhekekar, N.V.Srikanth, " A novel approach to dynamic stability enhancement using PID damped fuzzy susceptance controlled SVC", IEEE Power System Conference and Exposition PSCE 2011, pp. 1-6, March 2011.
- [11] N.G. Hingorani and L. Gyugyi, "Understanding FACTS, Concepts and Technology of Flexible AC Transmission System", Wiley-IEEE press, 1ed., Dec. 1999.
- [12] N.G. Hingorani. "High power electronics and Flexible AC transmission system", IEEE Power Engineering review, Jul. 1988.
- [13] N.G.Hingorani, "Flexible AC transmission systems", IEEE spectrum (40-45) April 1993.
- [14] Kundur P., Klein M., Rogers G.J. and Zywno M.S. "Application of power system stabilizers for enhancement of overall system stability," IEEE Trans. Power syst., vol.4, pp.614-626, 1989.
- [15] H.F.Wang, "Applications of damping torque analysis to STATCOM control", Elsevier, Electrical Power and Energy Systems 22, 2000, 197–204.
- [16] H.F.Wang, "Phillips-Hefron model of power systems installed with STATCOM and applications", IEE proceedings on generation, transmission and distribution, vol. 146, no.5, September 1999, pp 521-527.
- [17] Ustun, T.S. and S. Mekhilef, 2010, Effects of a Static Synchronous Series Compensator (SSSC) based on a soft switching 48-pulse pwm inverter on the power demand from the grid. J. Power Elect., 10:85-90.
- [18] Mohammad reza safari tirtashi, ahmad rohani , reza noroozian,"PSS and STATCOM controller design for damping power system oscillations using fuzzy control strategies", proceedings of ICEE 2011.

Author's Profile

Patel Pinkeshkumar has received his Bachelor of Engineering degree in Electrical Engineering from S V M Engineering College, Chincholi, Nasik (MH) in the year 2009. At present he is pursuing M. Tech. with the specialization of Power System in Surabhi College of Engineering and Technology. His area of interest Power system, Electrical Machines, Renewable energy sources, Power Distribution and Transmission Systems.

Hitesh Lade has received his Master of Technology in Power Electronics. At present he is working as an Associate Professor at Surabhi College of Engineering and Technology, Bhopal, MP. His areas of interests are Power electronics, Electrical Drives, Power Systems, Renewable Energy Sources and Custom Power Devices.